

# ABC Service Box Plus

## 200A rated



### Overview and presentation

- Pole or wall mounted distribution boxes for aerial bundled connectors, open wire conductor overhead line distribution systems or underground supply cables

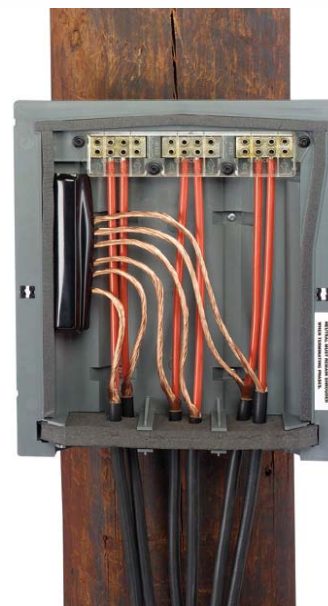

Type 1a ABC service box mounted to pole



### Features

- Tough, fully insulated construction designed for outdoor installation
- Accommodates up to 9 service cables balanced over three phases
- Versions with either 50mm<sup>2</sup> or 95mm<sup>2</sup> incoming terminals
- Choice of CNE or SNE configurations
- External Earth variant
- Transparent insulating shields over Phase terminals (Flexible shroud over N/E terminal)
- Sealing wire facility in 4 positions
- Twin M8 hexagon drive pinching screws per conductor (4mm hexagon head)
- Connections situated at top of enclosure giving maximum space for cable spreading
- All terminal blocks have serrated bores suitable for stranded or solid cable
- Outgoing cables exit through bottom mounted closed cell foam cable bush
- Captive quick release fasteners for temporary retention of cover in open position

**Note:** The equipment described on this data sheet must be installed by suitably qualified personnel according to applicable Local/ National Wiring regulations currently in force.

# ABC Service Box 200A rated



## Construction

- Enclosure...ASA (Acrylic Styrene Acrylonitrile)
- Terminal blocks .....Electro tin plated brass
- Neutral terminal block shield..... Flexible PVC
- Phase terminal block shield..... Polycarbonate
- Wall mounting bracket .....Aluminium



## Performance

- Rated voltage..... 415V a.c.
- Rated current ..... 200A
- Supply frequency..... 50-60Hz
- Flammability rating.....UL94 VO, self-extinguishing 30 seconds at 960 degrees C
- Operator protection
  - Cover in place.....IP43
  - Cover removed.....IP2X
- Terminal torque.....3.5Nm



## Product characteristics

### ■ Terminal capacities

		SUPPLY (Incoming)	SERVICE (Outgoing)
Type 1a	CNE	6-50mm <sup>2</sup>	6-50mm <sup>2</sup>
Type 1b	SNE	6-50mm <sup>2</sup>	6-50mm <sup>2</sup>
Type 2a	CNE	35-95mm <sup>2</sup>	10-70mm <sup>2</sup>
Type 2b	SNE	35-95mm <sup>2</sup>	10-70mm <sup>2</sup>

All variants accommodate a total of 9 outgoing service ways



## Conformity to Standards

- Complies with ENATS 43-14
- IP rating to BSEN 60592



## Dimensions

- Height..... 380mm
- Width..... 312mm
- Depth..... 114mm



## Weight

- Net weight .....1.7 kgs to 1.9 kgs depending on specification / variant

**ABC Service Box**  
200A rated



**General arrangement and dimensions (mm)**

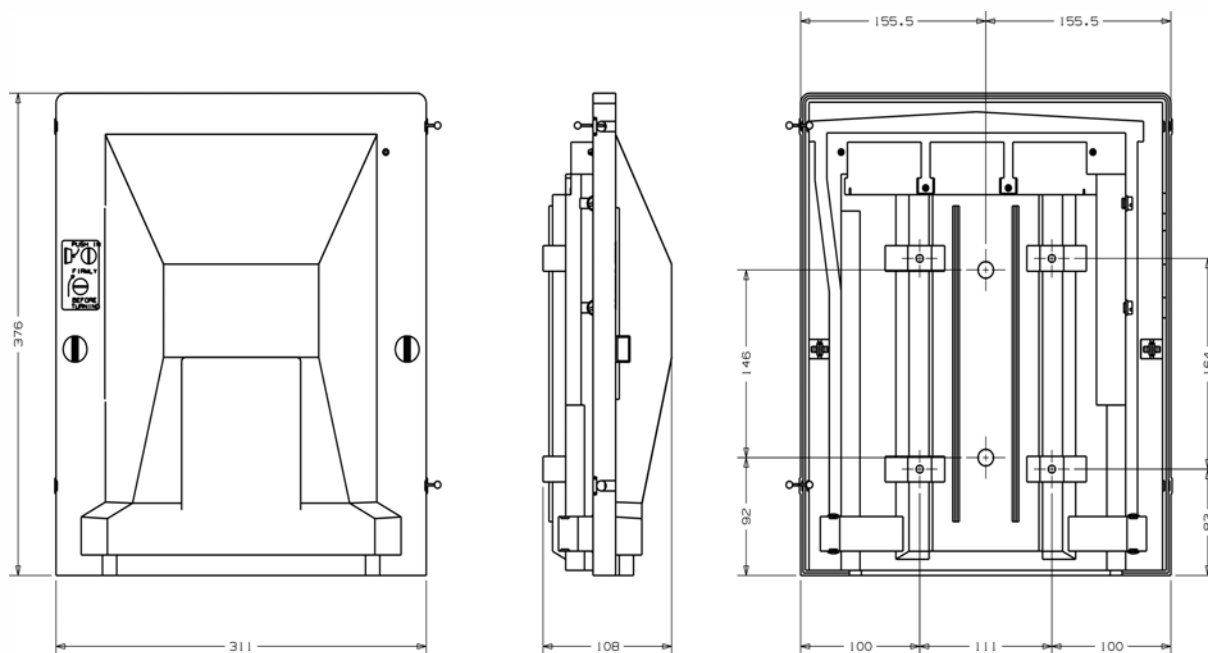

	Fixing centre dimensions (mm)	
	Vertical spacing	Horizontal spacing
<b>Wall mounting (4)</b>	164	111
<b>Pole mounting (2)</b>	146	n/a

**Disclaimer**

Lucy Switchgear has a policy of continuous research and development and accordingly reserves the right to change the design and specifications of its products without prior notice or liability.

**Lucy Switchgear**

Howland Road, Thame,  
Oxfordshire, OX9 3UJ, UK  
**Tel: +44 (0) 1844 267267**  
Fax: +44 (0) 1844 267223  
Email: sales@lucyswitchgear.com

**Lucy Middle East**

PO Box 17335, Jebel Ali,  
Dubai, United Arab Emirates  
**Tel: +9714 883 2110**  
Fax: +9714 883 2113  
Email: sales@lucyme.ae

**The Saudi Lucy Company Ltd**

PO Box 834, Al-Khobar,  
31952, Saudi Arabia  
**Tel: +966 3 8823057**  
Fax: +966 3 8822553  
Email: info@saudilucy.com

